

SVS CEILING LIFTS

For Small Projectors/Cameras

SVS ES12P Series



PRODUCT FEATURES

Designed to support projectors and small cameras, the SVS ES12P lift is a cost effective and convenient solution to conceal the projector out of sight use. This compact lift lowers 12" [305mm] below the false ceiling.

- Supports small cameras & projectors (up to 21" Wide x 14" Deep with lens)
- Maximum Travel Distance: Adjustable to 12" [304.8 mm]
- Two positions: Up and Down (projector/camera is stored in the ceiling when not in use and lowered for viewing).
- Easy Mounting Installation
- Smooth and quiet lifting mechanism
- Warranty: 5 Year parts, 1 year motor & 90 day factory labor

SPECIFICATIONS

Overall Unit Size (1)	HEIGHT	Raised	15-3/4" [400 mm]
		Lowered	27-3/4" [705 mm]
	WIDTH	Top Frame	20" [508 mm]
		Platform	21" [533 mm]
DEPTH	Overall	21-5/8" [549 mm]	
	Top Frame	4.5" [116 mm]	
	Bottom Frame	16-1/8" [410 mm]	
Retracted Height with Closure & Plenum Shroud (2)	17-3/8" [441mm] with ceiling closure 19-3/8" [492mm] with closure & plenum shroud are used.		
Lowering Distance	12" [305 mm]		
Maximum platform dimensions (W x D)	21" x 17" [533.4 mm x 431.8 mm]		
Maximum projector size (W X D)	21" X 14" [533 mm x 355.6 mm]		
Ceiling closure dimensions (W x D) (3)	15/16" T-Bar:	22-7/8" x 22-7/8" [581 mm x 581 mm]	
	9/16" T-Bar:	23.1/4" x 23.1/4" [590.5 mm x 590.5mm]	
Lifting Capacity	up to 50 lbs [22.68 kg]		
Net Weight	45bs [20.4kg]		
Approx. Shipping Weight	60 lbs [27.2 kg]		

(1) Dimensions of lift - (2) Lift's supporting structure is additional.
(3) Custom platform/ ceiling closure sizes available

STANDARD SPECIFICATIONS

Voltage	110v/220V, 60/50hz
Current Draw	.54 amps [110v], .27 amps [220v]
Control Voltage	24 VAC (contact closure)
Materials	Steel/Aluminum

RECOMMENDED ACCESSORIES

#1A Closure – Lipless spring-loaded ceiling closure. Can be used with dry wall ceiling- supplied unpainted.

FP1 Ceiling Closure -Lipped or Lipless fixed mounted ceiling closure panel. Can be used with dry wall ceiling. Supplied unpainted.

#2 Plenum Shroud – Protective Metal cover for projector & lift in air plenum rated ceiling.

FRONT VIEW RETRACTED

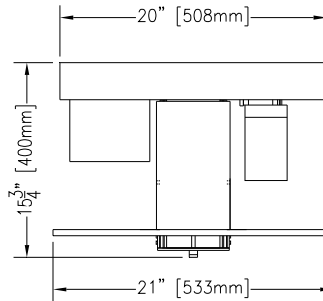

FRONT VIEW EXTENDED

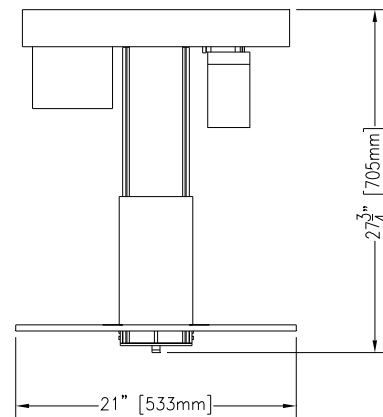

SIDE VIEW

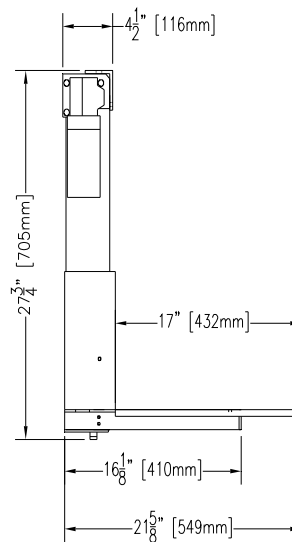

TOP FRAME

